

NCRS AUSTRALIAN CHAPTER

NEWSLETTER



Special March 2015 Edition Car of the Month Member Neil Pimlet



President

Murray Forman

Vice President

Harry Turner

Secretary

Wendy Forman

Treasurer

Dianne Turner

Membership Officer

Joe Caruana

Merchandise

Richard Dickens

Webmaster

Gary Cowans

Editor

Wendy Forman

No. Plate Registrar

Andrew Mavin

Event Co-ord.

Andrew Christopoulos

Committee

Richard Stones

Rod Grogan

Ross Reynolds

Public Officer

Murray Forman

State Representatives

Western Australia

Terry Martin

Ph: 08-9443-1944

South Australia

TBA

Queensland

Bryan Wharton

Ph: 0413980420

New South Wales

Murray Forman

Ph: 02-4567-8330

Victoria

Scott Morden

Ph: 0438-944-308

Note: The State Rep is normally the first point of contact for enquiries regarding NCRS Australia membership or general club info. Enquiries from Tasmania covered by VIC Rep, from NT covered by SA Rep

This Issue:

- Presidents Report
- Vice Presidents Report
- Secretaries Report
- Editors Report
- Treasurers Report
- Welcome New Members
- Things For Sale
- Road Tour to Convention 2015
- Road Tour Form
- Fremantle Form
- Brisbane Form
- Funny Joke
- 61 Diff Ratio Judging School
- 1965 L78 Corvette Power steering
- Events Calender
- Members Car
- Advertising and Sales
- NCRS Aust Clothing
- Sponsors, Websites
- Membership For

Club Contact Details:

NCRS Australia Inc. PO Box 207 Kurmond NSW 2757

President: Murray Forman (02) 4567-8330, eagleviews@bigpond.com

Vice President: Harry Turner 0409409599 c5harry@live.com.au

Editor: Wendy Forman 0488906364 eagleviews@bigpond.com

OFFICE BEARERS



President: Murray Forman



Vice-Pres.: Harry Turner



Secretary: Wendy Forman



Treasurer: Di Turner



Editor: Wendy Forman



Web Master: Gary Cowans



Merchandise Richard Dickens



Event Co-Ord: Andrew Christopoulos



No. Plate Reg: Andrew Mavin



Membership Officer Joe Caruana

COMMITTEE MEMBERS



Rod Grogan



Ross Reynolds



Richard Stones

STATE REPRESENTATIVES



SA TBA WA: Terry Martin



QLD: Bryan Wharton



NSW: Murray Forman

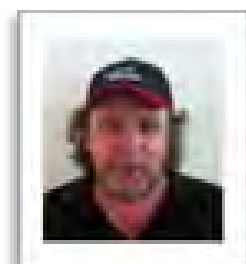

VIC Scott Morden

Presidents Report - Murray Forman

President Report Special Feb edition 2015

Hi Everybody the Editor and I thought we would do a special extra Newsletter in February. Because we would like to inform you about the upcoming Events that we are doing that you can participate in. In the Newsletter you will find all the application forms for these events.

EVENTS WE ARE DOING

1. We are holding a Judging meet in Brisbane over the weekend of 7th 8th March
2. We are holding a Judging meet in Perth over the weekend of 14th 15th March
3. We are doing a road tour from Sydney to the Canberra National Convention leaving from Kurrajong on the 31st March taking three days to arrive in Canberra.
4. We are holding an International Mark of Excellence Chapter Meet in Sydney at Kurrajong Hills on May 23rd – 24th TBA on the forms.
5. We are holding a judging meet in Melbourne at the Chevrolet Car Club in October. TBA on the forms.

Please support your Chapter and participate in these events as participation will keep the enthusiasm going in our Chapter.

All of these events are great fun and we look forward to sharing them with you all. Our Membership Officer has sent out the renewals for your Membership. If you are intending to renew your membership, please fill out the form at the bottom of this Newsletter and send it to:
NCRS Australia Inc.
P.O.Box 207
KURMOND NSW 2757

Murray Forman
President

Vice Presidents Report

There is no Vice Presidents Report in this edition

Secretaries Report

There is no Secretaries Report in this edition.

Editors Report – Wendy Forman

EDITORS REPORT

As I stated in my last report, we are now having Members Car of the Month on the front page of the Magazine with a small editorial inside.

Up until now, I have only received one member's car and editorial, without your input it is very hard to produce an interesting magazine. Please send in photos and small stories on your car and yourself.

We are also now running a For Sale Section for anyone who wishes to sell anything corvette related. So once again, please help by supplying a couple of photos with price, phone number and editorial.

I also need photos and stories of our member's experiences ie; holidays, car shows, technical information, anything that would be interesting for our other Chapter Members to read.

The Editors job is to produce a newsletter and if I don't receive any input from our members, it will be a pretty boring.

I am not asking a lot, just some content that I can use.

Wendy Forman eagleviews@bigpond.com

I hope you enjoy this extra edition.

Look forward to hearing from you.

Wendy Forman
Editor

Welcome New Members

There are no new members this edition.

Things For Sale

1968 Original style Reproduction Delco Battery
\$250.00 Contact Murray 0402917400 Great Condition



NCRS Aust Rd Tour to Canberra National Convention 2015

Taking in the Heart Country of New South Wales

Day 1 Tuesday **Kurrajong to Parkes.** 285km.
March 31st

Meeting at Murray & Wendy Forman's 7.45 am for a 8.15 am departure.
Visiting Bathurst for a "Scenic Drive" of Mt Panorama. With m/t at Bathurst.
Whilst at the Mountain we'll race into the National Motor Racing Museum.
A short drive up the Road to Orange for lunch.
Heading West now to Parkes to inspect the CSIRO Radio Telescope.
The star of the movie "The Dish". Time permitting the Henry Parkes Centre home of the Elvis Exhibit, Parkes Motor Museum & Antique Machinery Collection.
O/n in Parkes at the Spanish Lantern Motor Inn. Just next door to the HPC.
62 Newell Hwy. Pam 6862 3388 Double \$95.00 Single \$85.00

Day 2 Wednesday **Parkes to Griffith.** 307km.
April 1st.

Meeting at 8.15 am for a 8.30 am departure.
Via Forbes where "The Dish" was filmed. Back in 1862 Frank Gardiner & Ben Hall executed the biggest Gold robbery in Australia's history. (2719 oz)
A quick visit to the McFeeters Motor Museum & m/t.
Motoring South/West now through West Wyalong then onto Aria Park for lunch at the local Pub c1915. Aria Park is known for its Wowers, Bowers & Peppercorn Trees that line the streets. The village also caters for those shopping for arts, crafts & antiques.
Off to the West taking in a Winery or two or three as we approach Griffith
O/n in Griffith at the Acacia Motel. 923 Jondaryan Ave. Alan. 6962 4422
Std Double \$111.00. Better than Std \$119.00 Single \$109.00

Day 3 Thursday **Griffith to Harden.** 302km.
April 2nd.

Meeting at 8.15 am for a 8.30 am departure.
First stop Leeton for m/t & viewing the vibrant Art Deco Architecture this town has to offer.
Driving East now into Coolamon for Lunch.
The Up-to-Date Store is an example of an early 1900's general emporium.
It houses a very rare Lamson Cash Railway System.
A short drive to the historic town of Junee.
The Roundhouse Rail & Transport Museum houses the largest rail turntable in the Southern Hemisphere. (100ft built in 1947). Time permitting, calling into the nearby Licorice & Chocolate Factory.
Not far to Harden for our "Last Night Out" O/n in Harden at the Harden Motel.
42-50 Albury st. Alison. 6386 2377 Double \$102.00. Single \$89.00

Day 4 Friday. Drive into Canberra for day one of the National Corvette Convention.
April 3rd. Enjoy meeting new & old friends over the Convention period.

Any questions please do not hesitate to call. Mb 0409 409 599.
All Motels have off-street parking & are trailer friendly.

Hopefully you can join along.
Harry Turner
Vice President NCRS Australia Inc.

For Information about this Event please go to www.Corvettesofcanberra.org.au

Down Load the Brochure and Entry form

Corvette Capers In The Capital

27th National Corvette Convention 3-5 April 2015





NCRS AUSTRALIA

Road Tour To National Convention
CANBERRA 2015

EVENT REGISTRATION FORM

NAME

VEHICLE:.....REGO NO;.....INSURANCE:.....

POLICY NO:.....

NCRS AUSTRALIA INC invites you to attend our road tour to the Nationals in Canberra 2015

*NCRS Event Family Registration Fee (**Registration required ASAP, no later than 1st March 2015**)..... \$25.00
Registers 1 NCRS member and their immediate family (spouse/companion & kids under 23yrs)

*NCRS Event Guest/Extended Family Registration Fee: #___ @ \$25 each.....total

TOTAL \$_____

NOTE: PLEASE ARRANGE YOUR OWN ACCOMODATION FOR THIS EVENT

DAY 1 MARCH 31 PARKES - SPANISH LANTERN MOTOR INN 0268623388

DAY 2 APRIL 1 GRIFFITH – ARCADIA MOTEL 0269624422

DAY 3 APRIL 2 HARDEN – HARDEN MOTEL 0263862377



NCRS AUSTRALIA

Chapter Judging Meet

Fremantle 2015

EVENT REGISTRATION FORM

NAME

NCRS AUSTRALIA INC invites you to attend our Judging Meet to be held the Tradewinds Hotel

59 Canning Hwy, East Fremantle 6158 on 14th and 15th of March, 2015.

We will be staying at the Tradewinds Hotel.

*NCRS Event Family Registration Fee (**Registration required ASAP, no later than 27th Feb 2015**).....\$50.00

Registers 1 NCRS member and their immediate family (spouse/companion & kids under 23yrs)

- *On-site Registration ONLY after 28th Feb, incurs an additional \$25 fee.*

*NCRS Event Guest/Extended Family Registration Fee: # ___ @ \$25 each.....total \$ _____

*Judging Fee: Flight - \$75 *NOTE: Mandatory if you wish to have your car judged.....* \$ _____

- *Note: there is a limit to the # of cars to be judged, selection at the sole discretion of the Event Chairman*
- *Selection Criteria: timeliness of Registration; variety of cars; # of Judges attending*

* Sportsman Fee - \$20. *Note: non-Judged corvette displayed, receives Sportsman* \$ _____

*Daily Lunch \$20 per person, per day. *Indicate number of people & which days...* \$ _____

- # on Friday [] # on Saturday [] # on Sunday []

*NCRS Australia Cap: # _____ @ \$20 each One size fits all \$ _____

*Green Polo Shirt \$45.00 [] S [] M [] L [] XL [] 2XL [] 3X \$ _____

*Blue Denim Shirt \$45.00 [] S [] M [] L [] XL [] 2XL [] 3XL \$ _____

*NCRS Jacket. \$300.00 [] S [] M [] L [] XL [] 2XL [] 3XL [] \$ _____

TOTAL \$ _____

NOTE: PLEASE ARRANGE YOUR OWN ACCOMODATION RESERVATIONS.

Tradewinds Hotel 08 9339 8188

<http://www.tradewindshotel.com.au>

Make cheque payable to *NCRS Australia Inc* and mail cheque and registration form to:

- , NCRS Australia Inc, PO Box 207, Kurmond 2757, NSW, Australia.
- *For overseas registration, please be sure you mail a bank cheque (check) in Australian Dollars.*
- *Keep a copy of you registration and bring along to the Event*

Name _____ Guest _____

Address _____ City _____

State _____ Country _____ Post/Code -----

E-Mail _____ Chapter _____

Affiliation _____

Home _____ Phone _____ Work
Phone _____

Mobile/Cell Phone _____

(Please include your STD, Area and Country codes with the above phone numbers}

NCRS National (USA) Membership Number (See label on your Driveline or Corvette Restorer).. _____

NCRS Australian Membership Number

All other Corvette Car Clubs

NOTE: You must have both NCRS USA and Australian Chapter memberships to have your car judged in this event. Your Registration will not be processed without this information. For further information on USA membership, see <http://www.ncrs.org/> and click "Join Now". For Australian Chapter membership, see www.ncrs.com.au.

Car being entered for Flight Judging 1953-1994 or Sportsman – any era

Year _____ Complete VIN # _____

Coupe [] Convertible [] or Roadster [] please indicate which applies

All registrants (even if you are not having your car judged) must read and sign the Hold Harmless agreement as follows: (1) Whereas owner voluntarily enters his/her vehicle in the NCRS Australia event, the owner (s) will insure his/her vehicle against loss, damage, and liability and if asked, will provided proof of such insurance being in effect at the time of the event. (2) That the owner (s) does hereby indemnify and hold harmless NCRS Australia, all of its officers, directors, agents, employees or assigns for any such acts of omissions which may result in the theft, damage, or destruction or injury occurring during or as a consequence of this event, wherever located. (3) That owner(s) in attending this event does so voluntarily and agrees and assumes the risk of any and all damage to his/her vehicle or injury to his/her self or others, and NCRS Australia Inc or NCRS harmless there from. (4) The vehicle must be insured and "registered" to the person showing on the vehicle for judging. By signing your name in the designated area below, indicates that you have read and agree with these terms and conditions of entry and attendance.

Signature _____ **Date** _____



NCRS AUSTRALIA

Chapter Judging Meet

Brisbane 2015 EVENT

REGISTRATION FORM

NAME

NCRS AUSTRALIA INC invites you to attend our Judging Meet to be held at Mt Gravatt
Cnr Logan Rd & Springwood St Mt Gravatt March 7th / 8th 2015

Awards will be presented at the completion of the Judging Meet.

*NCRS Family Registration Fee (**Registration required ASAP, no later than 30th Feb 2015**).....
\$50.00
Registers 1 NCRS member and their immediate family (spouse/companion & kids under 23yrs)

*Judging Fee: Flight - \$75 *NOTE: Mandatory if you wish to have your car judged.....* \$ _____

- *Note: there is a limit to the # of cars to be judged, selection at the sole discretion of the Event Chairman*
- *Selection Criteria: timeliness of Registration; variety of cars; # of Judges attending*

*NCRS Australia Cap: # _____ @ \$20 each One size fits all..... \$ _____

*Green Polo Shirt \$45.00 []S []M []L []XL []2XL []3XL \$ _____

*Blue Denim Shirt \$45.00 []S []M []L []XL []2XL []3XL \$ _____

*NCRS Jacket. \$300.00 []S []M []L []XL []2XL []3XL [] \$ _____

TOTAL \$ _____

NOTE: PLEASE ARRANGE YOUR OWN ACCOMODATION FOR THIS EVENT

Please make your cheque payable to *NCRS Australia Inc* and mail cheque and registration form to:

- NCRS Australia Inc, PO Box 207, Kurmond 2757, NSW, Australia.
- *For overseas registration, please be sure you mail a bank cheque (check) in Australian Dollars.*
- *Keep a copy of you registration and bring along to the Even*

Name _____ Guest _____

Address _____ City _____

State _____ Country _____ PostCode _____

EMail _____ Chapter _____

Affiliation _____

Home Phone _____ Work Phone _____

Mobile/Cell Phone _____

(Please include your STD, Area and Country codes with the above phone numbers}

NCRS National (USA) Membership Number *(See label on your Driveline or Corvette Restorer)..* _____

NCRS Australian Membership Number

All other Corvette Car Clubs

NOTE: You must have both NCRS USA and Australian Chapter memberships to have your car judged in this event. Your Registration will not be processed without this information. For further information on USA membership, see <http://www.ncrs.org/> and click "Join Now". For Australian Chapter membership, see www.ncrs.com.au.

Car being entered for Flight Judging 1953-1994 or Sportsman – any era

Year _____ Complete VIN # _____

Coupe [] Convertible [] or Roadster [] please indicate which applies

All registrants (even if you are not having your car judged) must read and sign the Hold Harmless agreement as follows: (1) Whereas owner voluntarily enters his/her vehicle in the NCRS Australia event, the owner (s) will insure his/her vehicle against loss, damage, and liability and if asked, will provided proof of such insurance being in effect at the time of the event. (2) That the owner (s) does hereby indemnify and hold harmless NCRS Australia, all of its officers, directors, agents, employees or assigns for any such acts of omissions which may result in the theft, damage, or destruction or injury occurring during or as a consequence of this event, wherever located. (3) That owner(s) in attending this event does so voluntarily and agrees and assumes the risk of any and all damage to his/her vehicle or injury to his/her self or others, and NCRS Australia Inc or NCRS harmless there from. (4) The vehicle must be insured and "registered" to the person showing on the vehicle for judging. By signing your name in the designated area below, indicates that you have read and agree with these terms and conditions of entry and attendance.

Signature _____ **Date** _____

Funny Joke

Subject: Missing Wife

HERE'S YOUR SMILE FOR THE DAY !

A husband went to police station to report his missing wife:

Husband : I've lost my wife, she went shopping yesterday and has still not come home.

Sergeant : What is her height ?

Husband : Oh, 5 something . . .

Sergeant : Build?

Husband : Not slim, not really fat.

Sergeant : Color of eyes?

Husband : Never noticed.

Sergeant : Color of hair?

Husband : Changes according to season.

Sergeant : What was she wearing?

Husband : Dress/suit/blue jeans -- I don't remember exactly.

Sergeant : Did she go in a car?

Husband : yes.

Sergeant : What kind of car was it?

Husband : 2015 Corvette Stingray 3LT with the Z51 Performance Package, shark gray metallic paint, with the 6.2 litre V8 engine with Direct Injection generating 460 HP. 8-speed paddle- shift automatic transmission, and GT bucket seats, and has a very thin scratch on the front left door.....

at this point the husband started crying...

Sergeant : Don't worry sir.....We'll find your car...

1961 Corvette Differential Ratio determination & Judging School Event, Wangara, West Australia, January 2015

What's my rear axle ratio? That's the question Richard Geiger asked about his 1961 Corvette.

We know that 1958 -62 Corvette rear axles should have a round metal ratio identification tag attached to the rear axle housing stud at the 2 o'clock position above the casting number and date. Also, on 1953 through 1962 rear axles, the rear axle identification number should be stamped on the passenger side of the rear axle housing at the axle centre line. But what if over the years the identification tag has been lost and you cannot read or cannot find the stamped numbers, as was the case with Richards Corvette.

So we decided to find out what his ratio is.

We placed the Corvette on a four point hoist, transmission in neutral with the park brake off.



Once the Corvette was elevated and hoist locked, a horizontal chalk mark was drawn on the drive shaft and a vertical mark on one rear wheels.



Rotate the wheel one full turn while counting the drive shafts rotation. The drive shaft rotations on the 61 for one wheel rotation came to slightly over four turns. This indicates the rear axle ratio of 4:11. Other ratio's that might be found for 1955- 1962 Corvettes are 3:70, 3:55, 3:36, 3:08, 4:56.



Gary Wilkinson gave a one hour presentation on the overall standard deduction guidelines and use of the Judging Reference Manual prior to the event.

Members attending were;

David Moroney, Les Vanderweide, Richard Geiger, Terry Martin, Neal Bishop and Gary Cowans

1965 L78 Corvette Power steering Conversion & NCRS Judging School Event, Wangara, West Australia, February 2015

Gary Cowans says his 65, 396/425 is perfect except for the heavy steering. Perhaps he is getting old! So he decided to add power steering as a bolt on option in which the Corvette could be returned to manual steering should a future owner so desire.

He ordered the parts as below from Volunteer Vette in the US.



The conversion took place as an NCRS event at Terry's Professional Corvette Garage (Terry's Shed) in Western Australia.

Prior to starting the conversion Gary Wilkinson gave a one hour judging school presentation on the Matrix Judging Process using Finish, Date, Installation, Configuration & Completeness, (FDICC) on wheels & tyres.



The work required entailed relocating the alternator with new brackets, installing the power steering pump & brackets, replacing the Pitman Arm and Relay Rod. Two new belts are required to change the configuration as below.

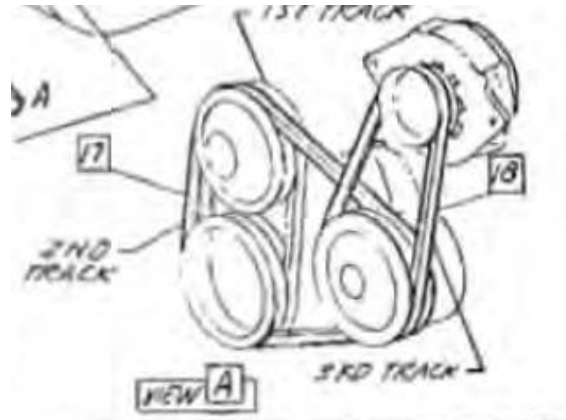
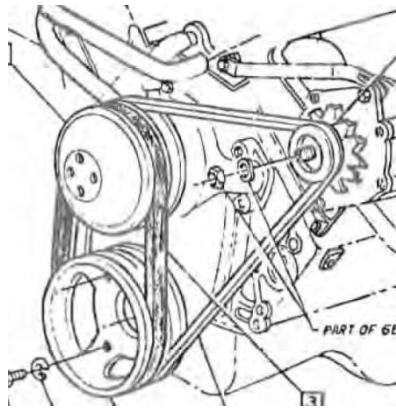

As the Alternator will now be powered from the front groove on the Power Steering Pulley a new Alternator Pulley as below is required.

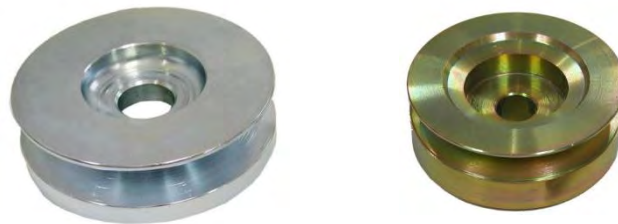

To enable the steering alignment to be set back to the same toe in after changing the drag link a reference was measured between the front wheels.

Work commenced under the hood removing and modifying the Alternator and removing the Alternator Brackets.

The Power Steering Pump was installed on the new mounting bracket and fastened to the front of the engine block. This proved to be easier than installing the bracket first and fitting the pump later as the rear mounting bolt on the pump is difficult to install with the bracket on the block.

The new Alternator Brackets and Alternator were installed next.



The Corvette was then raised on the hoist and the Relay Rod was removed after disconnecting the Tie Rod ends, Pitman Arm and Idler Arm.

We tried to pull the Pitman Arm from the Steering Box while the box was mounted on the chassis but we couldn't engage the puller correctly. Removing the box made the process easier.



The new Pitman Arm was located matching the splines on the old arm and torqued to 160Nm. The box was then reinstalled back in the car. The Power Steering control head was

fitted to the new Relay Rod and fitted to the Pitman and Idler arms underneath the Corvette.

This was followed by installing the Power Cylinder bracket to the chassis and then connecting the cylinder to the Relay Rod.



The Tie Rod ends were relocated to the forward holes (17.6:1 ratio) and all nuts tightened to and split pins fitted. The bolt an on the control head was then torqued to 50Nm.



Shift the Tie Rod ends to the forward hole. Fit the hoses to the control head as above.

Connect the hoses to the pump, relay rod and control valve. We found it easier to connect the large inlet pump hose to the control valve first before the others. Note that the hoses are crossed on the control valve.



The Hoses can be tricky to install on the power steering ram since they angle outward and slightly upward. Do not use a wrench to tighten these until you start them by hand and secure them with at least 3-4 turns manually. Before starting the engine, move the wheels right to left and left to right throughout the full range of travel watching the hoses for any possible friction or binding points. Be sure to look at the power steering pressure and return hoses for binding concerns as well.



Disconnect the ram nut at the bracket. Fill the power pump with fluid. Upon initial start-up, do not place your arm between the steering wheel spokes. A maladjusted control valve can cause the steering wheel to turn abruptly left or right on its own. The control valve should be adjusted to centre at manufacture as was case here. If the Ram moves in or out when the engine is started the control valve will require balancing. Remove the cap to gain access to the control valve balance adjustment 7/16" nut. Adjust the nut left or right to obtain zero movement of the Ram.

Finally swing the steering hard left and right to ensure there are no fluid leaks and road test.

Torque Chart

Item	Torque Nm
Steering sector shaft nut to pitman arm	160
Pitman arm to drag rod	60
Idler Arm to drag rod	60
Ball joint nuts	60
Steering box to chassis	130
Control valve to drag link bolt	27
Control valve to Pitman arm	60
Tie Rod clamp bolts	20
Power Ram to chassis bracket	30
Power Ram to Relay Rod	60
Power steering pump pulley	80



Job Done

Members attending were;

Allan Grime, David Moroney, Les Vanderweide, Richard Geiger, Terry Martin, Gary Cowans, Gary Wilkinson, Clint Messenger and Morten Benjaminsen.

NCRS Australia 2015 Calendar

FEBRUARY

Sunday 1st BBQ Eastern States at Rouse Hill Regional Park
Every Saturday WA Chapter Members meet at Terry Martins workshop starting 10am.

MARCH

Every Saturday WA Chapter Members meet at Terry Martins workshop starting 10am.
Sat 7th-8th Chapter meet Brisbane
Sat 14th-Sun 15th Chapter meet Fremantle Perth
Sunday 22nd BBQ Eastern States at Rouse Hill Regional Park
Tuesday 31st Road Tour from Sydney to Canberra

APRIL

Wed 1st - Fri 3rd Road Tour from Sydney to Canberra
Fri 3rd Mon 6th Australian National Convention Canberra
Every Saturday WA Chapter Members meet at Terry Martins workshop starting 10am.

MAY

Every Saturday WA Chapter Members meet at Terry Martins workshop starting 10am.
Sunday 3rd BBQ Eastern States at Rouse Hill Regional Park
Sat 23–Sun 24th IMO Chapter Meet Kurrajong Sydney

JUNE

Every Saturday WA Chapter Members meet at Terry Martins workshop starting 10am.
Sunday 21st BBQ Eastern States at Rouse Hill Regional Park

JULY

Every Saturday WA Chapter Members meet at Terry Martins workshop starting 10am
Sun 12 – 19th NCRS Road Tour from all areas to Denver
Mon 20 – 23rd NCRS National Convention in Denver Colorado

AUGUST

Every Saturday WA Chapter Members meet at Terry Martins workshop starting 10am
Sunday 9th BBQ Eastern States at Rouse Hill Regional Park

SEPTEMBER

Every Saturday WA Chapter Members meet at Terry Martins workshop starting 10am

Sunday 27th BBQ Eastern States at Rouse Hill Regional Park

2

OCTOBER

Every Saturday WA Chapter Members meet at Terry Martins workshop starting 10am

TBA Chapter Judging Meet – Melbourne

Sunday 18th NSW Corvette Car Club Car Show at Rouse Hill

NOVEMBER

Every Saturday WA Chapter Members meet at Terry Martins workshop starting 10am

Sunday 1st BBQ Eastern States at Rouse Hill Regional Park

Sunday 29th NCRS Australia Inc. AGM Venue TBA

DECEMBER

Every Saturday WA Chapter Members meet at Terry Martins workshop starting 10am

Saturday 5th NCRS Christmas Brunch Venue TBA

NOTE:

In Perth members meet every Saturday morning at Terry Martins workshop, the address is

3B Niche Rd, WANGARA WA

Please contact Terry on 0448-816067 if you wish to attend.

All Members and partners are welcome to the eastern states BBQ.

Please contact Harry Turner on 0409-409599. Should the weather be doubtful at Rouse Hill, the venue will automatically move to Harry and Di's home at Regent St, Riverstone

Some of the BBQ's will be changed to different members places on the dates allocated above.

We plan to update this calendar with each Newsletter.

If you wish to add anything to this calendar, ie; a car show, cruise.

Please let me know and the Committee will view your request.

Harry Turner 0409-409599 or c5harry@live.com.au

EXTRA NOTE As soon as we have notification of the date and venue for the Brisbane Chapter Meet we will add it to this calendar

Sydney to Canberra Road Tour – All States Welcome

Car of the Month

This is my 1969 matching numbers 427/390 Corvette convert in a rarer colour of Monaco orange with hard top as well.

I purchased this car from a qld collector back in may 2014,

Once this car arrived I was only able to drive it for about 3-4 hrs before it decided to drop 5 out of 8 piston rings into the sump ,with this there was no choice but to rebuild the engine witch was done in a meticulous manor, that now has the car sounding and performing like a big block should.

I have wanted one of these beauties since 1986 and after 30yrs of wanting I was able to purchase this car with my wife's consent as she said that when my father passes away we will replace the funds, got to love a good wife, as this is what was going to my dads legacy to me. The engine was on a bit of a rush list as dad was very sick with prostate cancer, thanks to all that helped as we were able to get it back on the road and after some anxious waiting I finally got to take him for a cruise and yes at the age of 83 he sat in a car and done his first burnout. This was the 23rd July 2014 and dad passed on the 20th November.

Hence I don't think this car will ever be sold outside of my family if at all.

I hope you all enjoy the pics

CHEERS

Neil Pimlett,
New Member Victoria



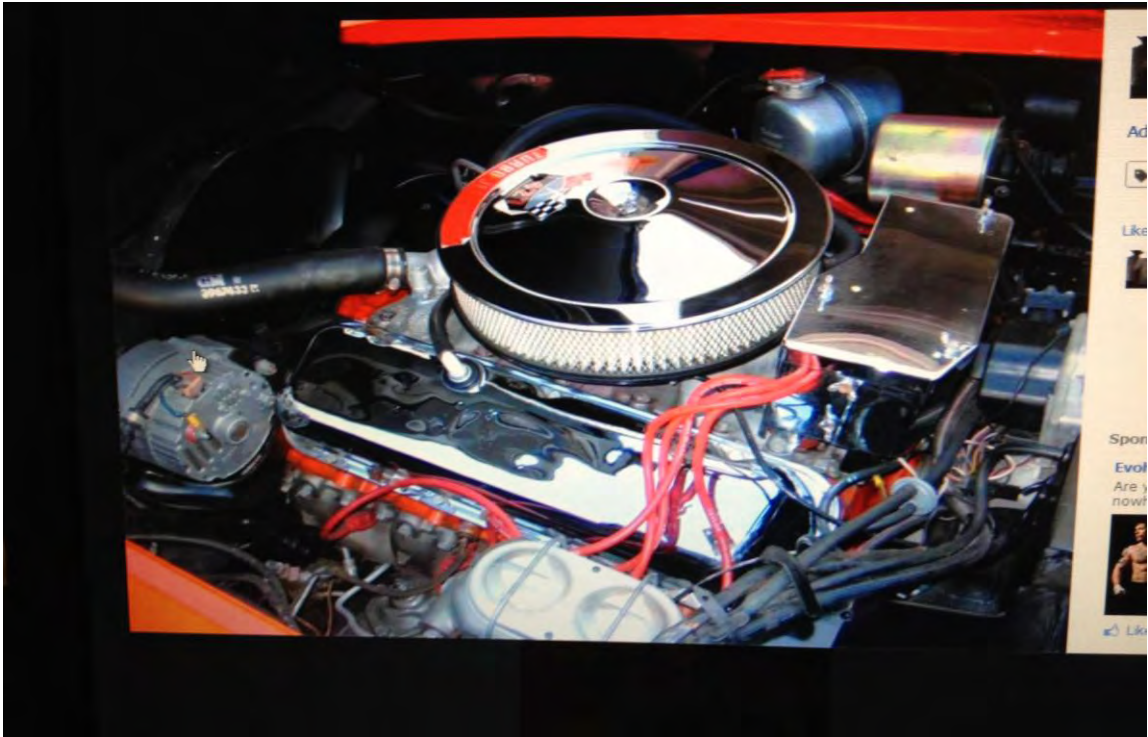



]

]

NCRS Apparel

BLUE DENIM \$35.00



GREEN POLO \$ 40.00



LADIES SHIRTS \$ 35.00



LEATHER JACKET \$300.00



WINDCHEATER JACKET \$45.00



WOOLLEN VEST \$38.00



CAP \$ 15.00



DRINK HOLDERS \$10



Sponsors



TRAVELMANAGERS
personally yours

I invite you to call me:

Debra Mavin

"Your Personal TravelManager" | 0418 732 557

"Without a Travel Agent You Are On Your Own"

debram@travelmanagers.com.au <http://my.travelmanager.com.au/debramavin>

TravelManagers Pty Ltd ABN 35113085626 Travel Agents Licence 2TA5758
Member TCF, IATA, AFTA, ICCA

MOTHERS[®]
Polishes • Waxes • Cleaners



Websites

NSW Corvettes Unlimited Car Club Inc.	www.nswcorvettes.com.au
NCRS USA	www.ncrs.org
NCRS Pittsburgh	www.NCRSPITT.com
NCRS Rocky Mountains	www.NCRSRMC.org
NCRS Texas	www.ncrstexas.org
Corvettes of WA Inc.	www.corvettesofwa.com
Qld Corvette Club Inc.	www.qldcorvetteclub.com.au
GM Corvette Assembly Plant	www.bowlinggreenassemblyplant.com
Corvette Forum	www.corvetteforum.com
National Council of Corvette Clubs	www.corvettesnccc.org
National Corvette Museum	www.corvettemuseum.com
Corvettes at Carlisle	www.carsatcarlisle.com
Bloomington Gold Corvettes	www.bloomingtongold.com
Chevy Vettefest	www.chevyvettefest.net

Membership Officers Report

NCRS Austral Inc. Club Membership - RENEWALS

- 12 month period runs from 1ST February to 31ST January of each year.
- Renewals are therefore due each February, reminder notices will be sent.
- Membership fee is \$50.00 per annum.
- Payments can be made by either:
 - EFT to NCRS Australia Inc, A/C No.10245414 BSB no. 062:595
 - PAYPAL: eagleviews@bigpond.com
 - Personal Cheque, Bank Cheque or Money Order made to NCRS Australia Inc. PO Box 207 Kurmond NSW 2757

Please note your membership numbers with all payments to ensure confirmation receipt by email.

General Enquiries: info@NCRS.com.au
Membership Enquiries: membership@NCRS.com.au
Membership Officer: Joe Caruana 0439 600 900



NATIONAL CORVETTE RESTORER'S SOCIETY AUSTRALIA INC.

P.O Box 207 Kurmond NSW 2757

www.NCRS.com.au

APPLICATION FOR MEMBERSHIP ---- RENEWAL

NCRS Membership No: _____ USA NCRS Membership No: _____
 Surname: _____ First Name: _____ Date of Birth: _____
 Address: _____
 Post/Zip Code: _____ State _____ Country _____
 H/ Phone: _____ W/ Phone: _____ M/ Phone: _____
 Email: _____ Occupation: _____
 Spouse /Partner Preferred Name: _____

CURRENT VEHICLE(S) OWNED (for publication in the Members Directory)

Please use the following code to denote condition: **(R)** Restored, **(UR)** UN Restoration, **(EO)** Excellent Original, **(GO)** Good Original, **(PO)** Poor Original, **(LH)** Left hand Drive. (If insufficient space – please attach a further, separate listing).

Year	Body Style	Registration No. <small>(indicate if not reg.)</small>	Colour	Condition <small>(Code as above)</small>	VIN ID Plate No.

I wish to renew my membership of NCRS Australia Inc. I agree to be bound by the current rules.

Please delete whichever is not applicable:

I DO NOT / I DO have any objection in having my vehicle details being included in the Members Directory circulated to all financial members.

I DO NOT OBJECT / I OBJECT to the above details being included in the Members Directory which will be circulated to all current financial members.

I AGREE / I DO NOT AGREE that I will not use the information contained in the Members Directory for any purpose other than to contact another member to discuss matters of mutual interest. I will not divulge the contents of the Members Directory to any other person or corporate entity.

Signature: _____ Date: _____

Renewal Membership Fee: **AUD \$50.00**
 Payment Methods: **EFT, Personal Cheque, Bank Cheque, Money Order or PayPal.**
 Banking Details: **A/C No: 10245414 BSB No: 062:595 (Please note membership number)**
 Payable to: **NCRS Australia Inc. PO Box 207, Kurmond NSW 2757 Australia**
 PayPal: **eagleviews@bigpond.com (Please note membership number)**

For office use only: Date Received: _____
 Receipt No: _____
 EFT/Cash/Chq/MO No: _____

General Enquiries: **info@NCRS.com.au**
 Membership Enquiries: **membership@NCRS.com.au**

National Corvette Restorer Society Australia Inc 9882798



NATIONAL CORVETTE RESTORER'S SOCIETY AUSTRALIA INC.

P.O Box 207 Kurmond NSW 2757

www.NCRS.com.au

APPLICATION FOR MEMBERSHIP

USA NCRS Membership No: _____ (if member)

Surname: _____ First Name: _____ Date of Birth: _____

Address: _____

Post/Zip Code: _____ State _____ Country _____

H/ Phone: _____ W/ Phone: _____ M/ Phone: _____

Email: _____ Occupation: _____

Spouse /Partner Preferred Name: _____

CURRENT VEHICLE(S) OWNED (for publication in the Members Directory)

Please use the following code to denote condition: **(R)** Restored, **(UR)** UN Restoration, **(EO)** Excellent Original, **(GO)** Good Original, **(PO)** Poor Original, **(LH)** Left hand Drive. (If insufficient space – please attach a further, separate listing).

Year	Body Style	Registration No. <small>(indicate if not reg.)</small>	Colour	Condition <small>(Code as above)</small>	VIN ID Plate No.

I wish to join the NCRS Australia Inc. I agree to be bound by the current rules.

Please delete whichever is not applicable:

I DO NOT/ I DO have any objection in having my vehicle details being included in the Members Directory circulated to all financial members.

I DO NOT OBJECT / I OBJECT to the above details being included in the Members Directory which will be circulated to all current financial members.

I AGREE / I DO NOT AGREE that I will not use the information contained in the Members Directory for any purpose other than to contact another member to discuss matters of mutual interest. I will not divulge the contents of the Members Directory to any other person or corporate entity.

Signature: _____ Date: _____

Renewal Membership Fee: **AUD \$50.00**
 Payment Methods: **EFT, Personal Cheque, Bank Cheque, Money Order or PayPal**
 Payable to: **NCRS Australia Inc. PO Box 207, Kurmond NSW 2757 Australia**
 Banking Details: **A/C No: 10245414 BSB No: 062:595 (Please note membership number)**
 PayPal: **eagleviews@bigpond.com (Please note membership number)**

For office use only: Date Received: _____
 Receipt No: _____
 EFT/Cash/Chq/MO No: _____

General Enquiries: **info@NCRS.com.au**
 Membership Enquiries: **membership@NCRS.com.au**

National Corvette Restorer Society Australia Inc 9882798